

1.4 High rigidity in all directions

The LM Guide withstands a load applied in any direction, whether vertical or horizontal. Since the groove is shaped as a circular arc, a preload can be applied to increase rigidity.

- Example comparing the static rigidity of the LM Guide with that of a feed screw system and a spindle (Vertical machining center with a 7.5-kW main spindle motor)

Component

LM Guide	: HSR45LB (C0) (Clearance = C0; preload = 6.43 kN)
Ball Screw	: BNFN4010-5 (G0) (Clearance = G0; preload = 2.64 kN)
Spindle	: general-purpose cutting spindle

Table 2 Comparison of Static Rigidity

			Unit: μm
Component	X-axis direction	Y-axis direction	Z-axis direction
LM Guide	–	2800	6600 (radial load) 4300 (reverse radial load)
Ball Screw	330	–	–
Spindle	250	250	280

Note: The rigidity of the feed screw system includes that of the bearings at the screw ends.

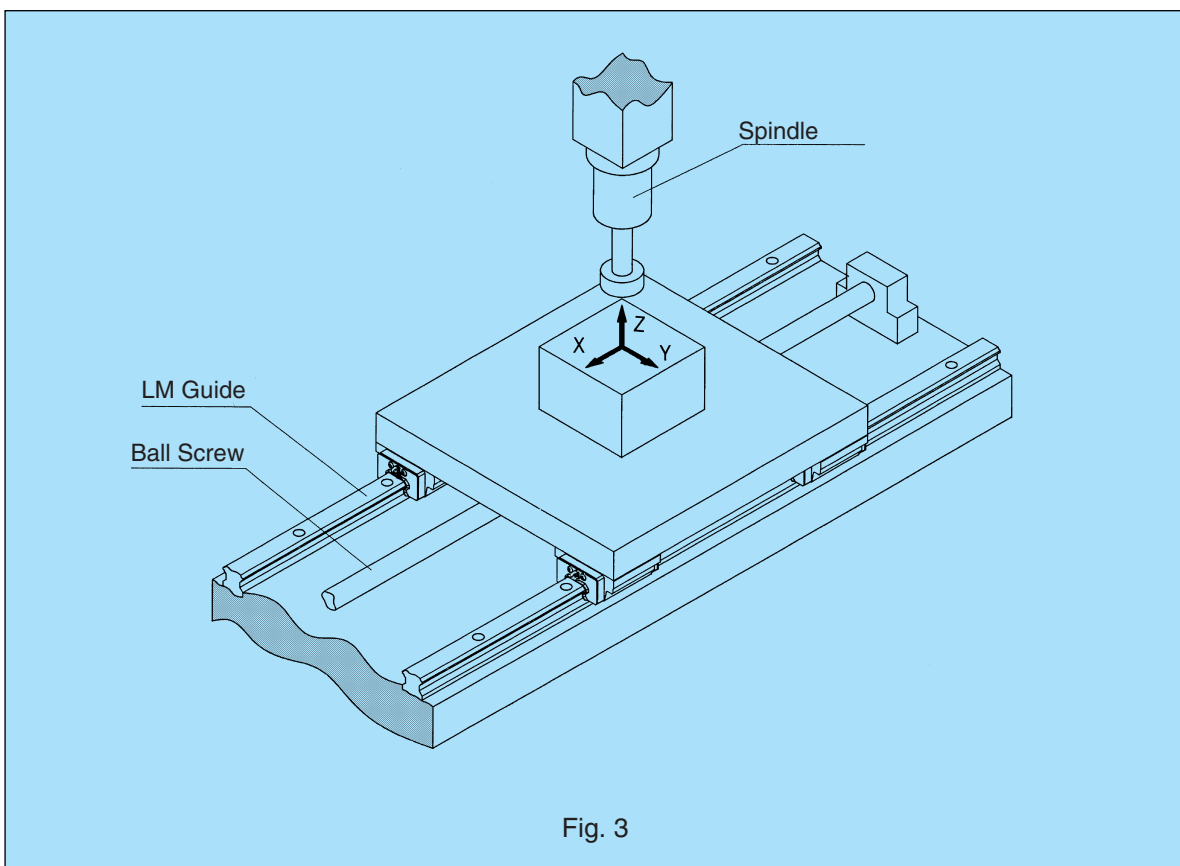

Fig. 3

As demonstrated above, the comparison of rigidity with the feed screw system and the spindle reveals that the rigidity of the guide surface when the LM Guide is used is far greater than when other devices are used.