

Seeking a clean source of electric power

THK has installed two vertical-axis wind turbines and one horizontal-axis wind turbine on the grounds of the THK INTECHS SENDAI Plant to serve as experimental equipment for research on and development of basic parts for wind turbine generators. Many applications are envisioned for small-scale vertical-axis wind turbine generators. In natural disasters such as the Great East Japan Earthquake of March 2011, they can be used to generate power in affected areas and supply power for mobile-phone base stations located in the mountains. Apart from emer-

gencies, small-scale wind turbine generators can also be used to power LED lighting in parking lots and parks and to light public spaces in and around large residential buildings. Large-scale horizontal-axis wind turbine generators, meanwhile, represent a pure domestic energy source that does not rely on fossil fuels. As a clean, environmentally friendly source of electric power, they are expected to become a primary energy resource in the future.

A safe source of electricity: The wind

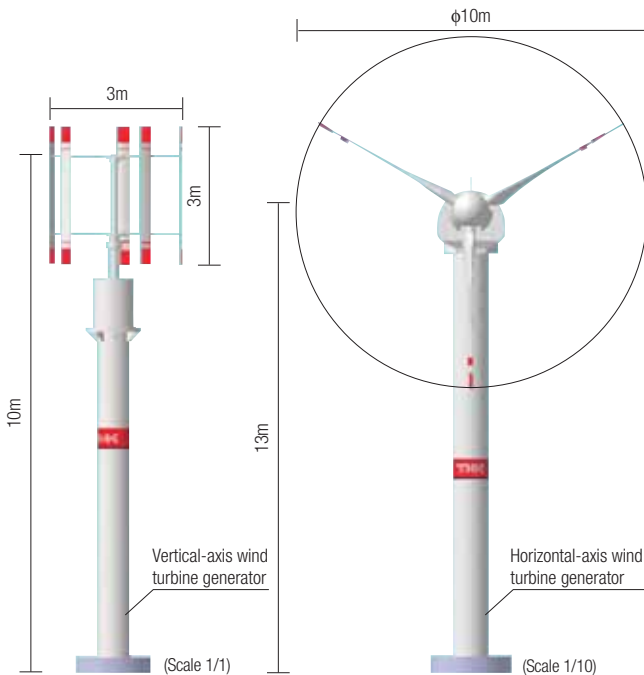

There are currently around 1,800 wind turbine generators installed throughout Japan, with a total capacity of 2.44 million kilowatts. Generally speaking, there are two types: vertical-axis wind turbine generators and horizontal-axis wind turbine generators. While the vertical-axis type has a comparatively low capacity, its construction is simpler because operation is not dependent on the direction of the wind. Horizontal wind turbine generators, which are mostly high-capacity generators, have to be pointed into the wind, which requires a more complex structure incorporating advanced technology.



Vertical-axis wind turbine generator



Horizontal-axis wind turbine generator

Vertical-axis wind turbine

	Inner rotor	Outer rotor
Rated power (kW)	3.2	3.2
Rotor diameter (m)	3	3
Swept area (m ²)	9	9
Number of blades	5	5
Rated wind speed (m/sec)	12.5	12.5
Cut-in wind speed (m/sec)	2	2
Cut-out wind speed (m/sec)	15	15
Survival wind speed (m/sec)	40	40
Emergency brake	Disk brake	Disk brake
Maintenance brake	Disk brake	Disk brake

Horizontal-axis wind turbine

Rated power (kW)	30
Rotor diameter (m)	10
Swept area (m ²)	78.5
Number of blades	3
Rated wind speed (m/sec)	12.5
Cut-in wind speed (m/sec)	2
Cut-out wind speed (m/sec)	15
Survival wind speed (m/sec)	40
Emergency brake	Brade feathering/yawing
Maintenance brake	Disk brake
Yaw control	Active yaw

Focal points

A look at the internal structure reveals the following about the vertical-axis wind turbine:

- (1) Commercial bearings do not fit the shaft diameter, so excessive power is required to turn the wind turbine. (There are no rolling-element bearings specifically designed for wind turbines.)
- (2) The wind turbine is equipped with a generator that converts wind energy to electric energy, but the wind turbine's output and that of the generator are based on different rates of rotation, so wind power can be utilized effectively only at certain rotation rates.

For the horizontal-axis wind turbine:

- (1) The part of the wind turbine that senses the wind direction and

swings the blades in that direction requires a large swivel ring equipped with gears. If the gears are damaged by wind vibration, it is difficult to replace them.

- (2) The mechanism incorporated in the blades that angles them in accordance with the wind intensity is controlled either by a hydraulic actuator or an electric gear. These can be damaged by the impact at certain wind intensities if the positioning is inaccurate or if there is too much clearance between gears.

Focusing on these and other problems, THK has theorized that they can be resolved by developing optimized parts and units using THK products. THK has therefore built vertical-axis and horizontal-axis wind turbines for experimental use.

THK ingenuity

THK will try to solve the problems described above by pursuing the following aims in its development efforts. For vertical-axis wind turbines:

- (1) Design the blades to turn easily even at low wind speeds, thereby increasing power-generating efficiency to accommodate any wind speed.
- (2) Provide customers with units equipped with built-in rolling-element bearings specifically designed for wind turbines, thereby reducing labor time devoted to assembly and adjustments.

For horizontal-axis wind turbines:

- (1) Replace some bearings with THK's removable R Guides, which enable replacement of the damaged section alone in the event that trouble develops at the pivot, thereby reducing replacement work.

- (2) Shift to a structure that combines various THK products to help minimize the clearance between gears and incorporate high-power output, energy-saving operation, and highly responsive electric actuators.



Future efforts and challenges

THK's trial efforts revealed the need for improvements in a number of areas:

- (1) Running vertical-axis wind turbines at a lower torque requires a shaft unit that is optimized for wind turbines.
- (2) It is known that a wind turbine will not rotate when its starting torque is greater than the wind-generated running torque at low wind speeds. Power generation at low wind speeds will therefore require a separate generator to help power the start-up phase.

- (3) It is necessary to reduce the risk of potential failure by providing a gearless yaw axis mechanism (for pointing the blades into the wind) on horizontal-axis wind turbines and to increase the gearless mechanism's capacity.

The above improvements will be reflected in future trial efforts, and development will continue with the expectation of eventual practical applications.

Protecting important assets during earthquakes

THK markets seismic isolation systems incorporating “LM Guides,” a flagship THK product, to minimize the shocks of earthquakes. After introducing the social value of these systems in detail in last year’s *CSR Report*, these systems proved highly effective in protecting buildings, servers and other important assets of our customers in the Great East Japan Earthquake that struck on March 11, 2011 and which was followed by the earthquakes with epicenters located in northern Nagano Prefecture and eastern Shizuoka Prefecture with a maximum seis-

mic intensity of 6.

To illustrate how THK’s seismic isolation systems contributed to protecting peoples’ lives and property and helped to ensure the continuity and reliability of social infrastructure and industrial activity, we will present the voices and opinions of some of those who decided to have them installed.

(Photo, left and center: House of Mr. Hiroshi Soutome and Mrs. Keiko Soutome, right: SHIZUOKA DAIICHI TELEVISION)

Seismic isolation systems ensure safe flights



Seismically isolated JAL servers

Some people may think that making a building earthquake-proof will protect important data from being destroyed. However, the hard disk of a server or other device that is inside of a building can be destroyed in an earthquake even if the building does not suffer damage or the hard disk itself is not hit and damaged by a falling object. Furthermore, think of the opportunity loss if a server were to topple over causing the system to go down. We felt a need to introduce the most effective method possible in order to avert this type of risk.

Japan Airlines manages large amounts of information on the servers of its data center including a system to support flight safety, its check-in system at airports and websites for booking flights. When the greatest earthquake on record struck on March 11, 2011, these systems remained completely unaffected by the earthquake because they were secured by THK’s seismic isolation system.

On the day of the earthquake, the Haneda and Narita Airports were shut down, grounding numerous flights. If the servers had broken down due to the earthquake, this would have seriously affected all

flights and the resumption of operations even to non-affected areas. The fact that the data center remained intact was a major feat for our company.

The idea of installing a seismic isolation system at the data center arose immediately after the Kobe Earthquake. There were a number of choices including decentralization of the data center. In the end, the decision was made to go with a seismic isolation system which promised a stabilizing effect with the lowest investment. At first, seismic isolators of another manufacturer were installed, but hearing reports that their isolation effect was insufficient, the decision was made to switch to THK’s seismic isolation system with top and bottom plates that stay in place.

Having now experienced the Great East Japan Earthquake, we are satisfied that our decision to install a seismic isolation system was a most prudent measure both in terms of cost and risk aversion.

Yuichi Osada

Manager, Corporate Support Systems, IT Planning,
Japan Airlines Co., Ltd.

Seismic isolation system for servers offers security



Osamu Matsuda

Manager
Engineering Department,
Corporate Planning Office
SHIZUOKA DAIICHI TELEVISION
CORPORATION

SHIZUOKA DAIICHI TELEVISION broadcasts TV programs to roughly 3.8 million citizens of Japan's Shizuoka Prefecture.

In the August 2009 Shizuoka Earthquake, the server running our important enterprise system was twisted out of shape and suffered other damage. It was then that I realized that broadcasting would face serious difficulties in a major disaster such as the yet to be experienced Tokai Earthquake, and so I took the plunge and ordered a seismic isolation system for our servers.

At the discussion stage, we were also considering the seismic isolations systems of other manufacturers, but:

- (1) THK holds the top share worldwide in linear motion systems, and its basic technology a high level of reliability,
- (2) Their seismic isolation systems utilize a unique rolling technology, and

- (3) The THK sales people are very convincing with their very sophisticated sales approach and strong confidence in their products.

In view of the above considerations, we decided in September 2010 to have THK products installed.

The Great East Japan Earthquake that struck on March 11, 2011 registered a seismic intensity of 4 in Shizuoka City. At the time, rolling motions that I have never before experienced continued for some time. All that happened was that the server racks moved gently in a horizontal direction, and the seismic isolation table shifted by about 5 cm. The seismic isolation systems had done their job right after being introduced. The servers did not suffer any damage, and we could sense the stability that was provided by the seismic isolation system.

Creating a new business combining house moving and seismic isolation work



**Mr. Hiroshi Soutome
and
Mrs. Keiko Soutome**

Soutome Construction Ltd.

Two years ago, we had to move our house because the municipal road next to it was about to be widened. This gave me the idea to be the first in our prefecture to combine house moving with seismic isolation technology. I then submitted a business innovation plan to the authorities, and became eligible for a Business Activities Promotion approved by the governor of Tochigi Prefecture.

We have been in business for 109 years, and I represent the fourth generation of house movers.* In college, I learned about the Urban Earthquake Disaster Prevention Plan, and I developed a strong interest in seismic isolation. Besides being engaged in house moving, I was attending regular meetings of the Seismic Isolation Society, and this is where I came in contact with the people of THK. When I heard that seismic isolators were installed at THK's UTSUNOMIYA Branch, I went there to have a look. I had also been exposed to the marketing campaigns for seismic isolators of other manufacturers, but when I saw the isolators that incorporated rolling technology, I was really impressed. I was so taken by the frequent visits and enthusiasm of the sales person that I decided to use THK's seismic isolators.

I was not in my house on the day of the Great East Japan Earthquake. At home, my wife, who gives lessons on how to

wear a kimono, was busy teaching her students. At my office, framed pictures apparently fell off the wall and scattered all over the floor. At home, however, not a single glass had broken, and it seems that my wife continued with her lesson. When our daughter-in-law, who had joined the lesson, returned to her home, some of her furniture had fallen over and household goods were strewn all over the floor. This made her realize for the first time the impact of the earthquake. Because of the frequent aftershocks, she stayed at our home that night where she felt relaxed enough to sleep. After that, aftershocks continued for a while and we could feel the ground trembling below us. Luckily our house was not at all affected and we have been able to continue our lives without incident. I realize that this is because of THK's seismic isolators that we installed in our home, and I am deeply impressed.

We are keeping our house open for anyone interested in taking a look at our seismic isolators. Please drop by and see for yourself. Going forward, I hope to be increasingly involved in construction work dealing with seismic isolation and the moving of shrines, temples and other important cultural assets. Doing this in cooperation with THK would be a real pleasure for me.

* House moving : A construction method used to comply with land readjustment measures for preservation and protection of historical buildings or moving structures to another location so they need not be knocked down.

In their own words >>> A local employee



Masami Kimura

Team Leader
Sales Section, UENO Branch
Sales Department, East Japan Region I

When I recommend a seismic isolation system to a customer, I provide a detailed explanation of the benefits and effects of installing such a system and the risks of neglecting to address the danger of earthquakes. My priority is to offer resolutions to a variety of potential problems that will not be easily overcome physically and financially.

For example, I think it is very important to convince customers that seismic isolation systems offer protection against actual losses due to damaged servers and the like, but I stress that they also need to think about the repercussions on society when servers fail. Seismic isolation systems not only contribute to physical and financial risk prevention, but also help to protect assets that cannot be expressed in numbers such as the trust of customers and society at large.

Recently, many of my customers reassure me, saying "It is a good product, so sell it with confidence and you will do just fine."