

Rack & Pinion - Z Stages 40 x 40

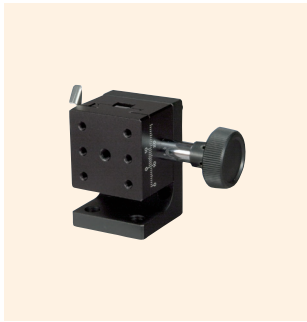

↑ TLV-412



↑ TLV-412W



↑ TLV-412S



↑ TLV-412WS

Features

- The travel unit uses a dovetail (D-T method) for the travel guide.
- A rack & pinion is used for the feed method, achieving large travel amounts.
- Versatile use for positioning of cameras, sensors, etc.
- A lever type clamp enables fixing in a desired position with strong retention force.
- Low bracket products with a short Z bracket are available.

Low bracket

Model number	TLV-412L	TLV-412WL	TLV-412SL	TLV-412WSL
Model name	DT Z Stage 40 x 40	DT Z Stage 40 x 40 (Double Knob)	DT Z Stage 40 x 40 (Coarse/Fine Movement Knob)	DT Z Stage 40 x 40 (Double Coarse/Fine Movement Knob)
Travel direction	Z-axis single direction			
Stage surface	40 mm x 40 mm			
Clamp method	Lever method			
Operating part mounting position	Single knob	Double knob	Single coarse/fine movement knob	Double coarse/fine movement knob
Feed method	Rack & pinion method			
Travel amount	10 mm			
Travel amount/1 knob rotation	Approx. 18 mm		Coarse movement: approx. 25.5 mm, Fine movement: approx. 3.3 mm	
Scale	Vernier reading: 0.1 mm			
Sensitivity	0.1 mm			
Travel guide	Dovetail			
Travel accuracy	Straightness: 0.03 mm			
Load capacity	19.6 N (2 kgf)			
Mass	0.23 kg	0.26 kg	0.3 kg	0.36 kg
Main materials/surface treatment	Aluminum alloy/black satin anodized finish			

Regular bracket

Model number	TLV-412	TLV-412W	TLV-412S	TLV-412WS
Model name	DT Z Stage 40 x 40	DT Z Stage 40 x 40 (Double Knob)	DT Z Stage 40 x 40 (Coarse/Fine Movement Knob)	DT Z Stage 40 x 40 (Double Coarse/Fine Movement Knob)
Travel direction	Z-axis single direction			
Stage surface	40 mm x 40 mm			
Clamp method	Lever method			
Operating part mounting position	Single knob	Double knob	Single coarse/fine movement knob	Double coarse/fine movement knob
Feed method	Rack & pinion method			
Travel amount	±10 mm			
Travel amount/1 knob rotation	Approx. 18 mm		Coarse movement: approx. 25.5 mm, Fine movement: approx. 3.3 mm	
Scale	Vernier reading: 0.1 mm			
Sensitivity	0.1 mm			
Travel guide	Dovetail			
Travel accuracy	Straightness: 0.03 mm			
Load capacity	19.6 N (2 kgf)			
Mass	0.26 kg	0.28 kg	0.33 kg	0.38 kg
Main materials/surface treatment	Aluminum alloy/black satin anodized finish			



Rack & Pinion Stages ◀ Manual Stages ◀

Product Appearance

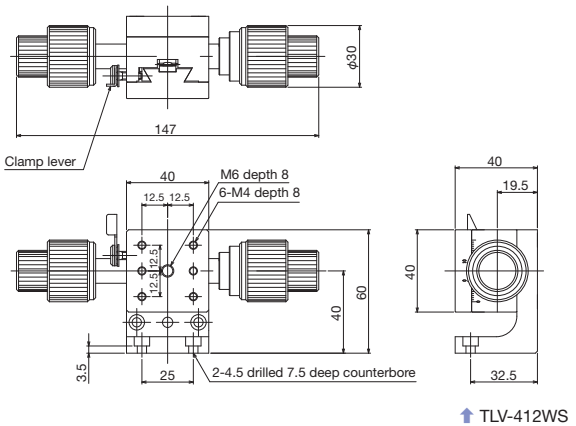
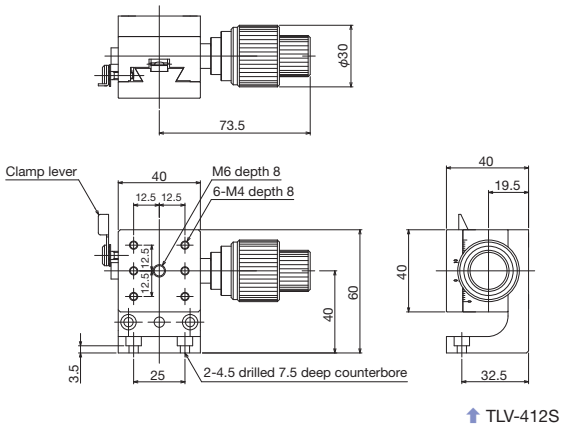
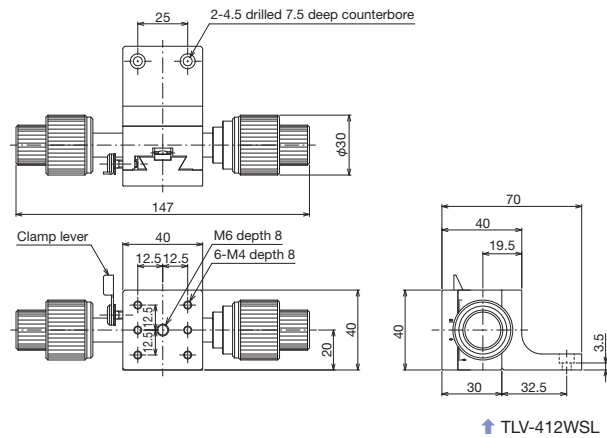
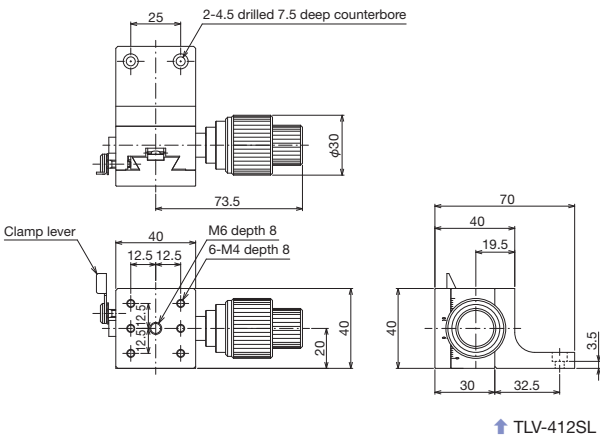
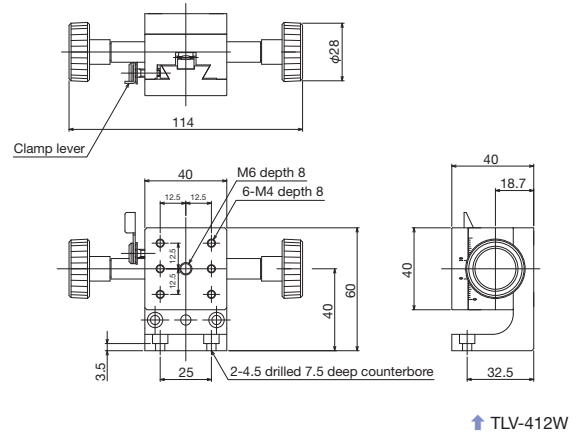
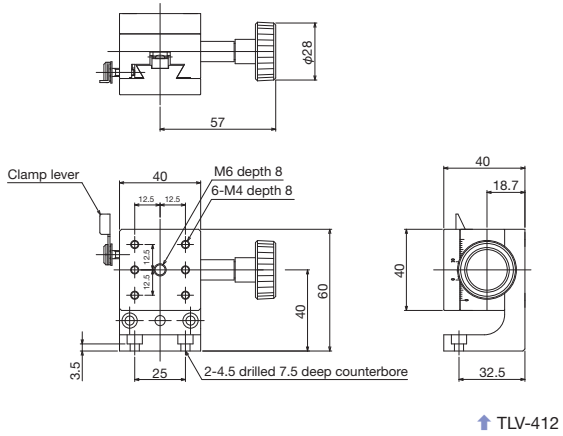
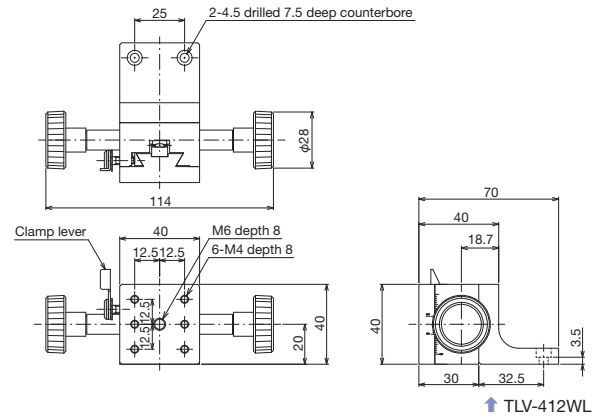
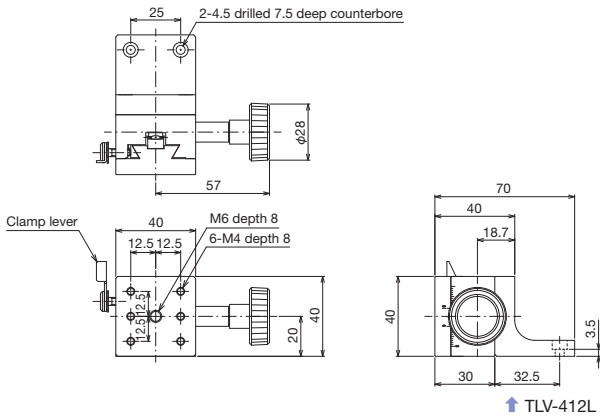

Motorized Stages	Automated Products for Microscopes
Fix Stages	Manual Stages
Thin VB Stages	
Rack & Pinion Stages	
High-Grade Stages	
Swim Stages, Cross Roller Stages	
Z-Like Stages, Z Stages	
Rotary Stages	
Tilt Stages	
Tilt/Rotary Stages	
XZ, YZ Stages	
XYZ Stages	

Rack & Pinion - Z Stages 40 x 60



↑ TLV-612



↑ TLV-612W



↑ TLV-612S



↑ TLV-612WS

Features

- The travel unit uses a dovetail (D-T method) for the travel guide.
- A rack & pinion is used for the feed method, achieving large travel amounts.
- Versatile use for positioning of cameras, sensors, etc.
- A lever type clamp enables fixing in a desired position with strong retention force.
- Low bracket products with a short Z bracket are available.

Low bracket

Model number	TLV-612L	TLV-612WL	TLV-612SL	TLV-612WSL
Model name	DT Z Stage 40 x 60	DT Z Stage 40 x 60 (Double Knob)	DT Z Stage 40 x 60 (Coarse/Fine Movement Knob)	DT Z Stage 40 x 60 (Double Coarse/Fine Movement Knob)
Travel direction	Z-axis single direction			
Stage surface	40 mm x 60 mm			
Clamp method	Lever method			
Operating part mounting position	Single knob	Double knob	Single coarse/fine movement knob	Double coarse/fine movement knob
Feed method	Rack & pinion method			
Travel amount	15 mm			
Travel amount/1 knob rotation	Approx. 18 mm		Coarse movement: approx. 25.5 mm, Fine movement: approx. 3.3 mm	
Scale	Vernier reading: 0.1 mm			
Sensitivity	0.1 mm			
Travel guide	Dovetail			
Travel accuracy	Straightness: 0.03 mm			
Load capacity	19.6 N (2 kgf)			
Mass	0.33 kg	0.35 kg	0.4 kg	0.46 kg
Main materials/surface treatment	Aluminum alloy/black satin anodized finish			

Regular bracket

Model number	TLV-612	TLV-612W	TLV-612S	TLV-612WS
Model name	DT Z Stage 40 x 60	DT Z Stage 40 x 60 (Double Knob)	DT Z Stage 40 x 60 (Coarse/Fine Movement Knob)	DT Z Stage 40 x 60 (Double Coarse/Fine Movement Knob)
Travel direction	Z-axis single direction			
Stage surface	40 mm x 60 mm			
Clamp method	Lever method			
Operating part mounting position	Single knob	Double knob	Single coarse/fine movement knob	Double coarse/fine movement knob
Feed method	Rack & pinion method			
Travel amount	±15 mm			
Travel amount/1 knob rotation	Approx. 18 mm		Coarse movement: approx. 25.5 mm, Fine movement: approx. 3.3 mm	
Scale	Vernier reading: 0.1 mm			
Sensitivity	0.1 mm			
Travel guide	Dovetail			
Travel accuracy	Straightness: 0.03 mm			
Load capacity	19.6 N (2 kgf)			
Mass	0.36 kg	0.38 kg	0.42 kg	0.48 kg
Main materials/surface treatment	Aluminum alloy/black satin anodized finish			



Rack & Pinion Stages ◀ Manual Stages ◀

Product Appearance

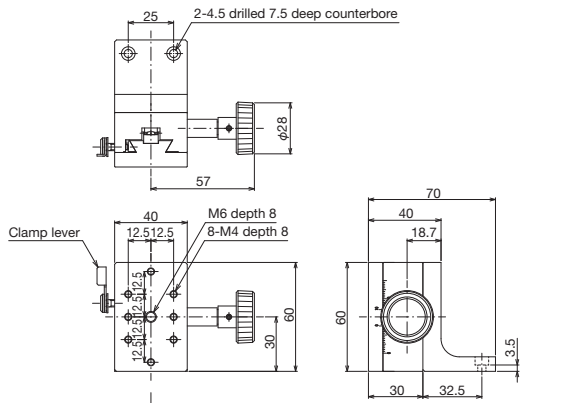

↑ TLV-612L

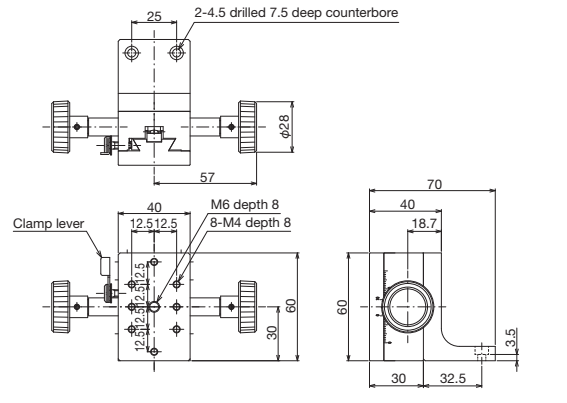

↑ TLV-612WL

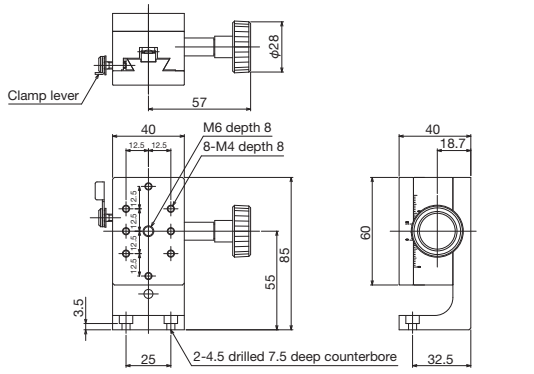

↑ TLV-612

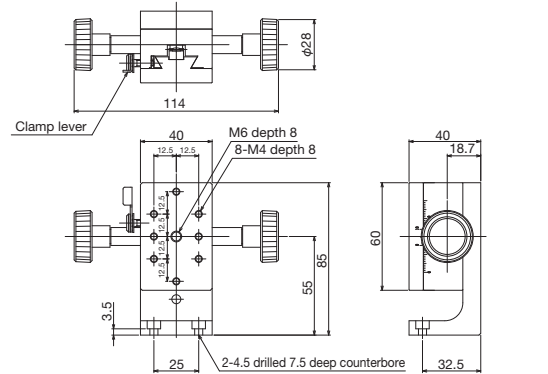

↑ TLV-612W

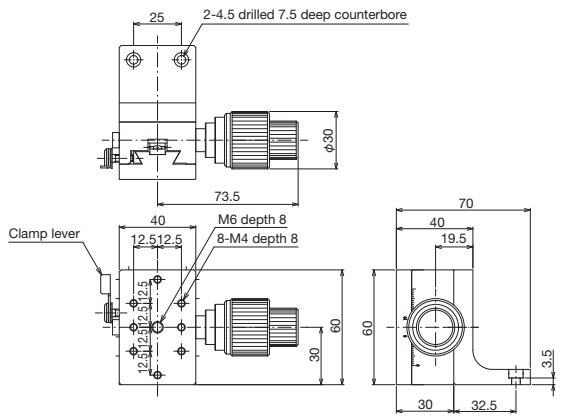

↑ TLV-612SL

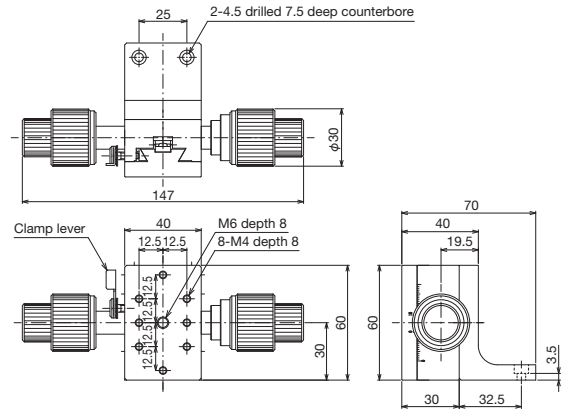

↑ TLV-612WSL

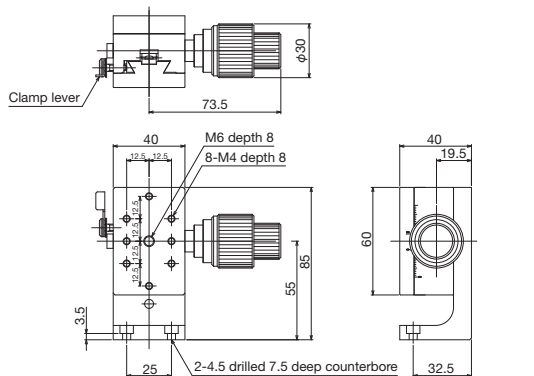

↑ TLV-612S

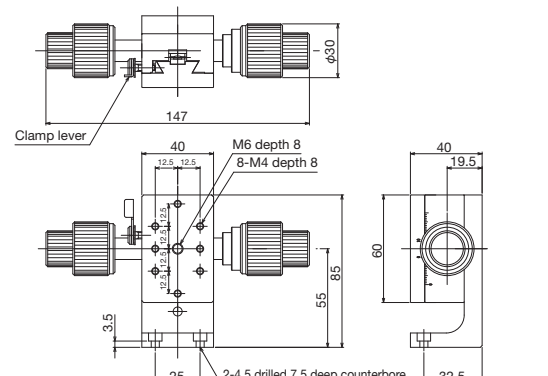

↑ TLV-612WS

Motorized Stages
Automated Products for Microscopes
Manual Stages
Fix Stages
Thin VB Stages
Rack & Pinion Stages
High-Grade Stages
Swim Stages, Cross Roller Stages
Z-Like Stages, Z Stages
Roddy Stages
Tilt Stages
Tilt/Retary Stages
XZ, YZ Stages
XYZ Stages