

Research and Development

Guided by the business philosophy of “providing innovative products to the world and generating new trends to contribute to the creation of an affluent society,” THK continually strives to create original products as a creative development-driven enterprise.

THK Product Development as a Contributor to Industrial Development

THK's concept toward business is based on the philosophy of “providing innovative products to the world and generating new trends to contribute to the creation of an affluent society.” This thinking has guided our drive to be a creative development-driven enterprise, enabling us to develop a varied stream of products since our establishment in 1971. Besides contributing to industrial development, these efforts have also resulted in THK steadily accumulating technical expertise that has been a primary source of growth.

THK developed the world's first linear motion (LM) guide. For the first 10 years after we started production and sale of these products in 1972, LM guides were primarily used in machine tools. During this period, we developed a series of new products to fulfill our customers' needs for increased precision and lower cost. In the 1990s, other industries—such as manufacturers of semiconductor production equipment and industrial robots—began to adopt THK products. We responded by developing various new products that were optimized for customer-specific applications and operating environments in these sectors.

In 1996, we pioneered the development on the world's first-ever LM guide using caged ball technology, an advance that enabled LM guides to operate without maintenance for much longer periods. Although such technology was already common in rotary bearings at that time, the problem was the need to cope with both linear and circular movements. This made it extremely difficult to develop ball cages with sufficient durability to move along straight lines or curves. THK successfully took steps to overcome this issue. LM guides based on caged ball technology not only provide the benefit of long-term maintenance-free use, but have also made a significant contribution to the development of high-speed, low-noise industrial machinery with longer productive lives, particularly in the machine tool and semiconductor production equipment sectors. The advance also paved the way for the development of LM guides for additional applications. Today, we continue to develop products that use caged ball technology. Besides LM guides, this range has expanded to include ball screws, ball splines and hybrid units, which combine LM guides and ball screws.

A Global R&D System for the Next Generation

Drawing on elite minds from the ACE, FAI and IMT divisions, with a particular focus on the Engineering Division, a task force engages in R&D activities, primarily out of the Technology Center located in Tokyo, in such wide-ranging products as linear motion systems—a core THK product—and diverse markets including mechatronics, consumer products and automobiles.

In April 2010, operations commenced at an R&D facility established within the head office of THK (CHINA) CO., LTD. in Dalian, Liaoning Province. This is the Group's first such overseas base. More recently, operations commenced at a new designated R&D Center in April 2012. This is helping to accelerate product development. Amid a Chinese market that continues to enjoy growth, the THK Group will develop products that address local needs in a timely manner by locating this R&D base at the point of demand.

Product Development in Fiscal 2012: Realizing the “cubic E” Concept

Leveraging creative ideas and the Group's unique technologies, the main theme of THK's current R&D activities is the “cubic E” concept, which embraces the three keywords “Ecological,” “Economical” and “Endless.” Based on this theme, we continued throughout fiscal 2012 to speed up development with the aim of extending the range of applications for our technologies while at the same time seeking to develop highly original and attractive products for launch 5–10 years in the future. Major achievement in fiscal 2012 included the development of products for a number of original applications. In the industrial machinery field, and again with an emphasis on mainstay LM guides and ball screws, we developed electric actuator-related new model products for use in areas where demand is projected to increase in line with the ongoing progress toward electric-powered living.

With regard to our endeavors in new business areas, the Group focused on further raising competitiveness particularly from the perspective of costs in the transportation equipment field. In this context, steps were taken to develop new crafting techniques, more compact and lightweight products as well as products for use in electric vehicles. In the seismic isolation and damping field, the Company developed the Inertial Rotary Damping Tube (iRDT), an effective damping system designed to counter prolonged ground motion in high-rise buildings. We also concentrated development efforts in a number of fields: renewable energy, including photovoltaic power generation; medical equipment; lifestyle-related fields, including housing; and consumer use as well as humanoid robots. As specific examples of these, we participated with Japan Aerospace Exploration Agency (JAXA) on the REX-J astronaut support robot (astrobot) technological experiment mission designed to ultimately support extravehicular activity (EVA) on the International Space Station. In this case, we were engaged in the development of a robotic hand fitted with a space environment-resistant actuator with small ball screws. Being developed as a range of elemental components in a robotics system for next-generation robots, our SEED (Smart End Effector Devices) Solutions won the outstanding performance awards in the component and software categories at the Fifth Robot Awards, organized by the Ministry of Economy, Trade and Industry and the Japan Machinery Federation and which recognize contributions to the creation of a robot market in Japan, high-potential robots and robot-related components.

Fiscal 2013 Policies and Initiatives

We plan to focus our efforts in fiscal 2013 on the efficient development of new products with the aim of expanding applications for THK technology further. Specifically, we will pursue themes such as customer convenience while promoting designs that incorporate the potential for enhanced productivity and quality. Moreover, by conducting in tandem basic and applied development activities, we will focus on developing products that can quickly generate commercial returns. Complementing these endeavors, and while strengthening our global development capabilities, the R&D base within THK CHINA will serve at the center of efforts to actively promote product development that addresses local market needs.

MAJOR NEW PRODUCTS DEVELOPED IN FISCAL 2012

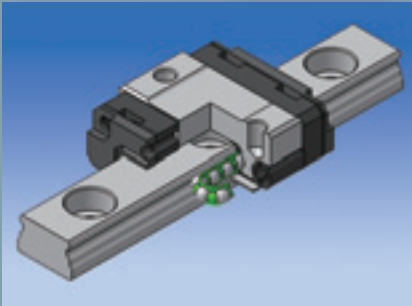

Miniature LM Guide: SRS-S/N

By expanding the block variations in miniature caged ball LM guides, we are now able to offer the caged ball structure across our complete miniature LM guide product lineup and thus meet a wide range of customer needs.



Precision Ball Screw: BIF-V

In our precision ball screw range, we developed the Model BIF-V. This product delivers superior performance due to such features as its low noise—achieved by the adoption of a new circulation system that picks up the ball in the tangential direction—its low torque variation and its high speed, which is around twice that of existing products.



Caged Ball High-Speed Ball Screw: SBKN

This model's service life has been extended to around six times that of existing products by the adoption of a double-nut system. Besides enabling high-speed operation due to its tangential pickup system, the fitting of the caged ball structure has realized long-term maintenance-free use and low-noise, smooth operation.



LM Guide Actuators: SKR55/65

We added the 55 and 65 to our Model SKR range of LM guide actuators. By adding variations, we have effectively doubled lead length. The fitting of the caged ball structure has realized long-term maintenance-free use and low-noise, smooth operation.

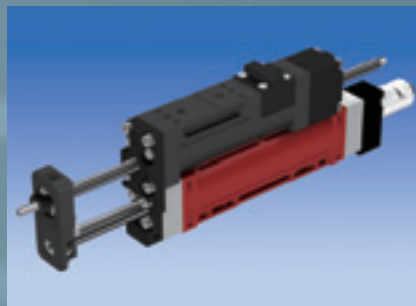

Multi-Motion Actuator: CCR

The Model CCR actuator facilitates independent linear and circular control. Its compact design with built-in encoder has realized device downsizing and high tact levels and also resulted in a product that has enabled the miniaturization of the pick-and-place unit and higher operating speeds of various devices.



Vibration Actuator: QBL

This handheld vibration actuator enables high-speed reciprocating motion. Specialized for vibration applications in magnetic circuits and bearing structures, the Model QBL's simple, easy-to-use configuration makes it the ideal product for all devices that utilize vibration.



Press Series: PCT

This is a cylinder-type electric actuator that uses ball screws. By replacing a pneumatic cylinder, this model realizes high tact levels, increased precision and multipoint positioning and can contribute greatly to improving the productivity of customer equipment.



Controller Series: TLC/THC

These devices are designed to control many different types of electric actuators. They cost less than other controllers yet come loaded with functions. In addition, only requiring the input of position information makes actuator operation easy even for beginners.